

WARNING!!!
READ THIS MANUAL BEFORE USE

OPERATOR'S MANUAL
FOR
XCR MEDIUM MODULAR RIFLE SYSTEM
(XCR-M)



ROBINSON
ARMAMENT CO.
925 W 100 North Suite A
North Salt Lake, UT 84054
www.robarm.com

© 2012 Robinson Armament Co. All Rights Reserved
Patented

WARNING

THE FOLLOWING ACTIONS ARE DANGEROUS AND MAY RESULT IN DEATH, SERIOUS BODILY INJURY, AND/OR DAMAGE TO PROPERTY. FOLLOW THESE WARNINGS AND THE OTHER WARNINGS AND INSTRUCTIONS CONTAINED IN THIS OPERATOR'S MANUAL CAREFULLY!!!

GENERAL WARNINGS

DO NOT HANDLE OR FIRE THE RIFLE BEFORE CAREFULLY READING AND UNDERSTANDING THIS MANUAL AND RECEIVING FIREARMS TRAINING FROM A COMPETENT INSTRUCTOR.

DO NOT FIRE THE RIFLE WITHOUT PROPER EYE AND HEARING PROTECTION BEING WORN BY THE OPERATOR AND ALL BYSTANDERS.

DO NOT HANDLE, DISASSEMBLE, OR ASSEMBLE THE RIFLE WITHOUT WEARING PROPER EYE PROTECTION.

DO NOT LOOK INTO OR PUT ANY PART OF YOUR BODY NEAR THE MUZZLE OR EJECTION PORT WHILE FIRING OR MANUALLY CYCLING THE RIFLE.

DO NOT USE ANY AMMUNITION OTHER THAN NEW, UN-DAMAGED, COMMERCIALY MANUFACTURED AMMUNITION WHICH MEETS SAAMI SPECIFICATIONS OF THE PROPER CALIBER FOR THE CONFIGURATION OF THE RIFLE.

DO NOT CHAMBER A ROUND UNLESS THE BARREL IS POINTED IN A SAFE DIRECTION.

WARNING

DO NOT FIRE THE RIFLE WITH ANY OBSTRUCTION OR WATER IN THE BARREL.

DO NOT STRIKE THE BUTT OF THE RIFLE ON THE GROUND OR ANY HARD SURFACE WITH THE BOLT HELD OPEN AND A LOADED MAGAZINE IN THE RIFLE.

DO NOT LEAVE A ROUND IN THE CHAMBER OF A RIFLE WHICH HAS BEEN FIRED 210 OR MORE ROUNDS WITHIN 5 MINUTES AS IT MAY SPONTANEOUSLY FIRE (COOK OFF).

DO NOT MANUALLY CLEAR A ROUND FROM THE CHAMBER IF THE RIFLE IS HOT AND IF THE ROUND HAS BEEN IN THE CHAMBER FOR MORE THAN 10 SECONDS.

DO NOT CONTINUE TO FIRE IF THE RIFLE SOUNDS MORE QUIET THAN USUAL OR THE RECOIL IS LIGHTER.

DO NOT POINT THE FIREARM AT ANYTHING YOU DO NOT INTEND TO SHOOT.

DO NOT PLACE YOUR FINGER ON THE TRIGGER UNTIL YOU ARE IN A STABLE SHOOTING POSITION AND HAVE THE INTENDED TARGET IN YOUR SIGHTS.

DO NOT FIRE THE RIFLE UNLESS YOU ARE SURE OF YOUR TARGET AND THERE IS AN ADEQUATE BACKSTOP.
DO NOT FIRE THE RIFLE AT WATER OR HARD OBJECTS.

DO NOT LEAVE YOUR RIFLE WHERE CHILDREN OR OTHER UNAUTHORIZED PERSONS WILL HAVE ACCESS TO IT.

(WARNINGS ARE CONTINUED ON THE NEXT PAGE.)

WARNING

XCR SPECIFIC WARNINGS

SET THE STOCK AT THE PROPER LENGTH SO THAT YOUR FACE IS AWAY FROM THE END OF CHARGING HANDLE SLIDE WHEN THE SLIDE IS FULLY RETRACTED. INSTRUCTIONS FOR SETTING STOCK LENGTH ARE FOUND ON PAGE 37.



DO NOT FIRE THE RIFLE UNLESS THE UPPER AND LOWER RECEIVERS ARE PROPERLY LOCKED. SEE PAGE 12.

DO NOT ATTEMPT TO LOAD OR FIRE THE RIFLE WITHOUT THE BARREL BEING PROPERLY INSTALLED. SEE PAGE .31

TABLE OF CONTENTS

RIFLE DESCRIPTION	1
SPECIFICATIONS	2
TERMINOLOGY	3-4
LOADING	5-10
FIRING	11-13
GAS ADJUSTMENT	13-14
BREAK IN	16
UNLOADING	15-16
DISASSEMBLY	17-23
CLEAN, INSPECT, LUBRICATE	24-29
ASSEMBLY	30-33
1913 RAILS/ACCESSORIES	34
CALIBER CONVERSION	35-36
FOLDING STOCK	37
TROUBLESHOOTING	38-39
WARRANTY/LIABILITY DISCLAIMER	40-41

The XCR is truly a unique rifle. It was designed from the ground up to have excellent ergonomics, accuracy, durability, reliability, and modularity.

Ergonomics. The XCRs controls were designed so that the operator can manipulate them while keeping his eyes and sights on target. The controls are ambidextrous and intuitive. These ergonomics give the operator a crucial time advantage when loading, changing magazines, or clearing malfunctions.

Accuracy. Though not designed as a match rifle, the XCR delivers great accuracy. Its fully floated barrel combined with a light two-stage trigger make consistent accuracy easy.

Reliability and Durability. Most rifles developed in the west are based on Eugene Stoner's AR-15/M-16 rifle. The XCR has more similarities to Mikhail Kalashnikov's AK-47. The XCR operates via a heavy duty, piston driven, rotating bolt combined with a strong extractor and solid ejector. These elements result in excellent reliability and durability.

Modularity. The XCR is truly a modular rifle system. The XCR has a serialized lower receiver to which can be added a variety of upper receivers accepting barrels in lengths from 7.5" to 18.6" in many different calibers. Its quick change barrel system allows caliber and/or barrel length changes in minutes. These features allow the XCR to be quickly configurable for any mission.

XCR-M (Medium)	Specifications (Mini & Standard)
Operation:	Piston Driven, 3 Lug, Rotating Bolt
Barrel:	Quick Change, Fully Floated
Calibers:	7.62 NATO (.308), .260 Rem., & more
Muzzle Threads	5/8x24
Muzzle Devices	Brakes, Flash Hiders, & Suppressors
Length Overall:	34" to 40"
Length Overall Folded:	25" to 31"
Weight (Empty):	8.5 to 10 Pounds
Upper Rail	Integrated, 18.5 to 20" 1913 Standard Rails
Side & Bottom Rails	Integrated, 8.15" to 9.5"
Magazines	SR-25 Type
Trigger	Two-Stage, 4.5 Pound Pull
Safety Selector	Ambidextrous, 45 Degree Throw
Magazine Release	Ambidextrous
Bolt Catch	Ambidextrous
Charging Handle	Left Side, Non-Reciprocating
Pistol Grip	Accepts AR-15/M-16 Grips
Stock Adjustment	Folding, Length, and Height
Stock Length of Pull	10.5" to 13.5" in 6 increments of .5"
Cheek Rest Adjustment	Two positions .25" Apart
Stock Height	Three Positions .25" Apart

TAKE TIME TO THOROUGHLY FAMILIARIZE YOURSELF WITH THE TERMS IN THIS SECTION DESCRIBING THE FEATURES AND COMPONENTS OF THE XCR AS THEY WILL BE REFERRED TO THROUGHOUT THIS MANUAL.

XCR MEDIUM FIELD STRIPPED

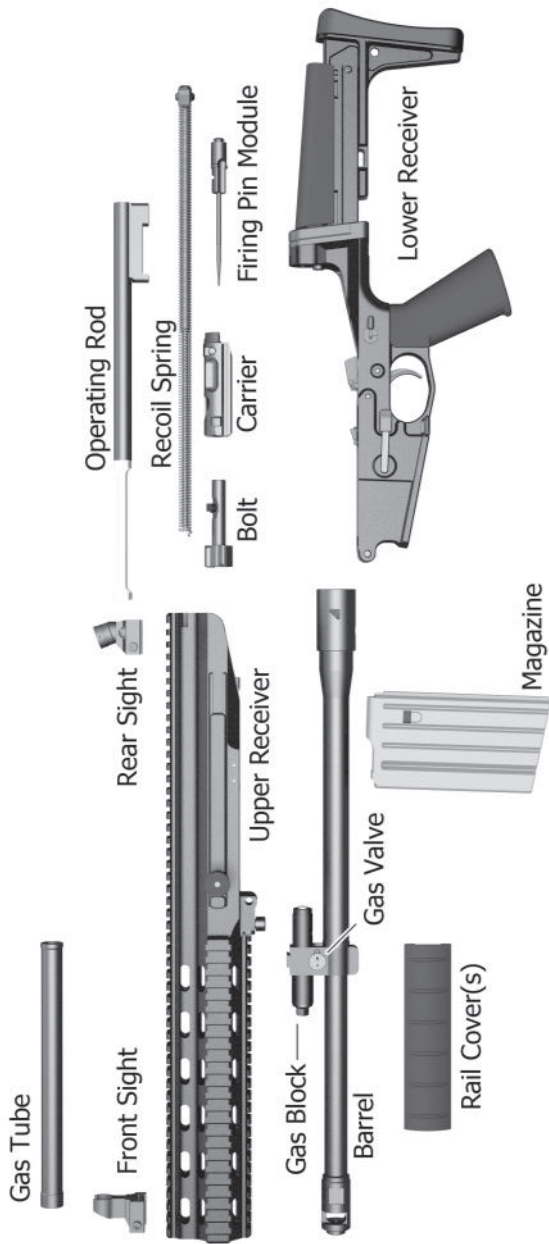

XCR MEDIUM RIGHT & LEFT VIEWS

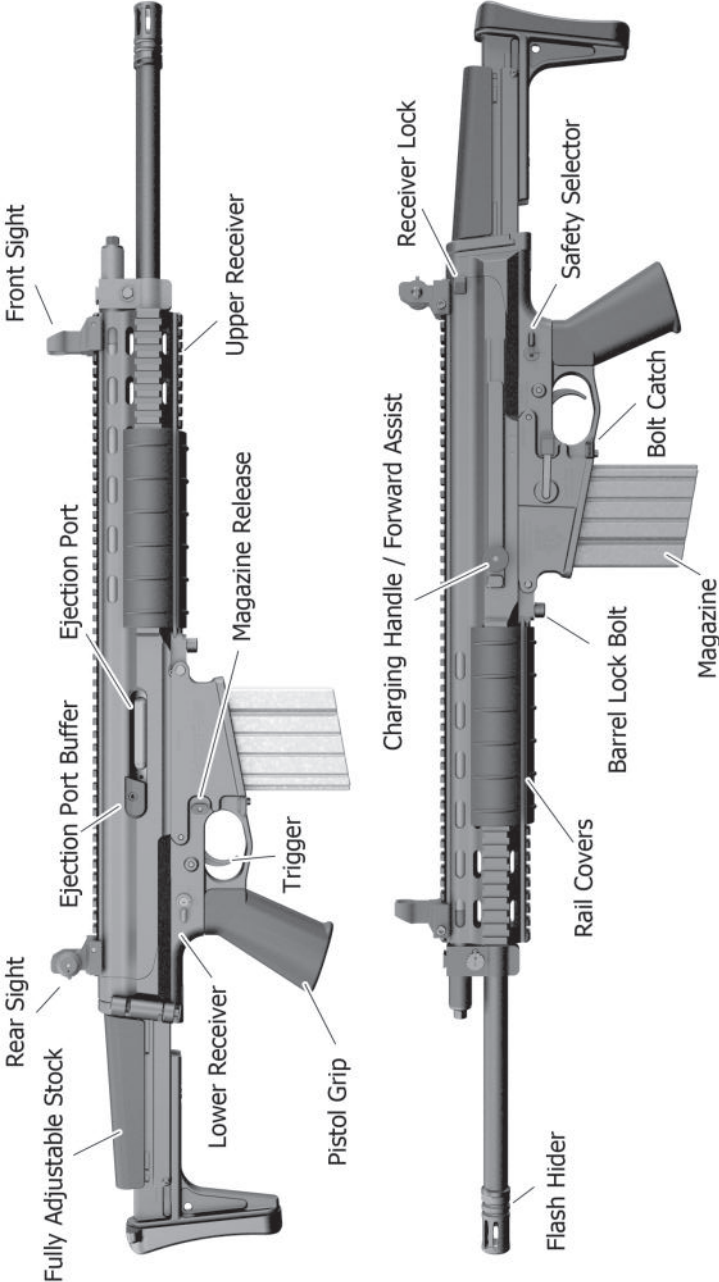

WARNING

USE ONLY NEW, UNDAMAGED, COMMERCIAL AMMUNITION MEETING SAAMI SPECIFICATIONS OF THE PROPER CALIBER WITH THE RIFLE. THE CALIBER OF THE RIFLE IS MARKED ON THE TOP OF THE BARREL NEAR THE MUZZLE. ALWAYS WEAR PROPER EYE PROTECTION WHILE HANDLING OR FIRING THE RIFLE.



1. Load a magazine of the proper caliber with the number of rounds for which the Magazine was designed. Do not overload the Magazine. If the Magazine is difficult to insert into the Rifle, you may want to reduce the number of rounds loaded in the Magazine by one or two rounds.



1. While pulling the Charging Handle fully to the rear with one hand, engage the Bolt Catch by pushing it upward with the index finger of your other hand.



2. Rotate the Selector so that the Indicator is next to the image of bullet with an X over it. This is the Safe position. (NOTE: The Safety Selector cannot be moved to the Safe Position if the rifle has been dry fired and the Charging Handle has not been pulled back.)



WARNING

KEEP THE RIFLE POINTED IN A SAFE DIRECTION AT ALL TIMES.

DO NOT INSERT A LOADED MAGAZINE INTO THE RIFLE UNTIL YOU HAVE MADE SURE THERE IS NO OBSTRUCTION IN THE BARREL OR CHAMBER. DO NOT LOOK DOWN THE BARREL UNLESS THE RIFLE IS UNLOADED AND THE BOLT REMOVED (SEE PAGES 15-16).

DO NOT STRIKE THE BUTT OF THE RIFLE ON THE GROUND OR ANY HARD SURFACE WITH THE BOLT HELD OPEN AND A LOADED MAGAZINE IN THE RIFLE.

3. To insert the Magazine in the Rifle, hold the rifle by the pistol grip with your dominant hand with your finger off the trigger. Insert a loaded magazine upward into the magazine well with your other hand.



4. While holding the rifle with your dominant hand with your finger off the trigger, firmly tap the magazine upward with the palm of your other hand.



5. Give the Magazine a good tug to make sure it is securely connected to the rifle.



WARNING

DO NOT CHAMBER A ROUND UNLESS THE BARREL IS POINTED IN A SAFE DIRECTION. KEEP YOUR FINGER OFF THE TRIGGER WHILE CHAMBERING A ROUND.

6. With the Bolt held in the open position by the Bolt Catch, depress the Bolt Catch with your trigger finger to close the Bolt and chamber a round.



LOADING (CONTINUED)

7. To chamber a round with the Bolt in the closed position, hold the Rifle with your dominant hand with your trigger finger off the trigger, and pull the charging handle back as far as it will go.



8. Release the Charging handle cleanly. Do not ride the charging handle forward.



Use of the Forward Assist.

The Rifle comes with a Forward Assist mechanism built into the Charging Handle. The purpose of the Forward Assist is to ensure the Bolt Carrier is fully forward after it has been withdrawn partially by the Charging Handle (as in the case of a chamber check).

WARNING

DO NOT FORCE A ROUND INTO THE CHAMBER. IF YOU CANNOT CHAMBER A ROUND, STOP SHOOTING IMMEDIATELY, UNLOAD THE WEAPON (SEE PAGES 15-16), AND CHECK THE CHAMBER, BORE, AND AMMUNITION.

DO NOT DEPRESS THE FORWARD ASSIST WHILE FIRING. DO NOT ALLOW ANYTHING TO DEPRESS THE FORWARD ASSIST WHILE FIRING.

The Forward Assist is used as follows: Pull the Charging Handle back until it engages the bolt. Then depress the Charging Handle while simultaneously pushing the Charging Handle forward.



WARNING

DO NOT FIRE THE RIFLE WITHOUT PROPER EYE AND HEARING PROTECTION BEING WORN BY THE OPERATOR AND ALL BYSTANDERS.

DO NOT LOOK INTO OR PUT YOUR FACE OR PART OF YOUR BODY NEAR THE EJECTION PORT OR CHARGING HANDLE WHILE FIRING OR MANUALLY CYCLING THE RIFLE.

DO NOT PLACE YOUR FINGER ON THE TRIGGER UNTIL YOU ARE IN A STABLE SHOOTING POSITION AND HAVE THE INTENDED TARGET IN YOUR SIGHTS.

DO NOT FIRE THE RIFLE UNLESS YOU ARE SURE OF YOUR TARGET AND THERE IS AN ADEQUATE BACK-STOP.

DO NOT FIRE THE RIFLE AT WATER OR HARD OBJECTS.

DO NOT ATTEMPT TO FIRE ANOTHER ROUND IF YOU EXPERIENCE ANY PROBLEMS WITH THE RIFLE WHATSOEVER. IMMEDIATELY STOP SHOOTING AND REFER TO THE TROUBLESHOOTING SECTION ON PAGES 40-41.

DO NOT LEAVE A ROUND IN THE CHAMBER IF YOU HAVE FIRED 210 OR MORE ROUNDS WITHIN A 5 MINUTE PERIOD. IT MAY SPONTANEOUSLY FIRE (COOK OFF).

WARNING

DO NOT MANUALLY CLEAR A ROUND FROM THE CHAMBER WHICH DOES NOT FIRE AFTER THE TRIGGER HAS BEEN PULLED UNTIL WAITING FOR 30 SECONDS.

NEVER FIRE THE RIFLE UNLESS THE UPPER AND LOWER RECEIVERS ARE PROPERLY LOCKED.

1. Make sure the Upper and Lower Receivers are properly locked. They are properly locked when the Receiver Lock is flush with the Lower Receiver as shown below.

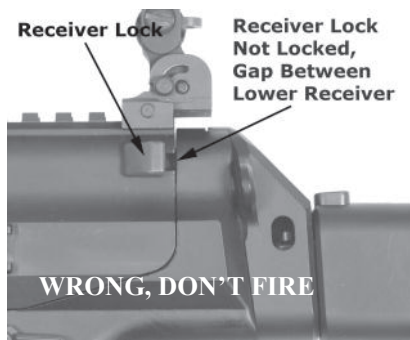
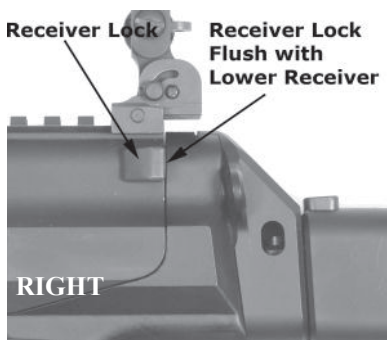

2. To fire the Rifle, rotate the Safety Selector so that the Indicator is next to the to the image of a bullet without an X through it. This is the Fire position. In this position, the Rifle is ready to fire if the trigger is pulled.

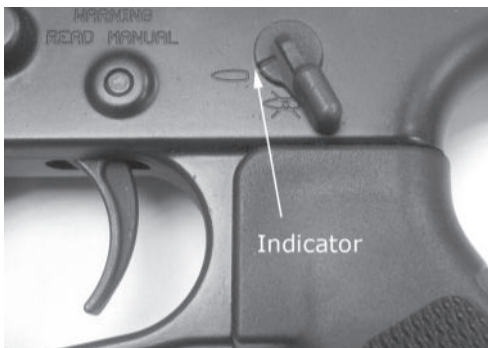

3. Pull the trigger. For each trigger pull, one shot will be fired until the magazine is empty.



4. When finished shooting, follow the Unloading procedure described on pages 15-16 of this manual.

WARNING

FOR SAFETY ALWAYS MAKE SURE THE RIFLE IS COOL AND ALWAYS POINT THE MUZZLE OF THE RIFLE IN A SAFE DIRECTION BEFORE MAKING GAS ADJUSTMENTS.

Gas Adjustment

The Rifle is equipped with an adjustable Gas Adjust Valve. The purpose of this device is to optimize the system for certain ammunition and for certain environmental conditions. The Gas Adjustment Valve has six Settings: Off (marked “0”) and 5 other settings. The detent determines which setting the valve is on with “-” being the

lowest setting and “+” being the highest setting. Rotation towards the “+” indicates a higher setting. Rotation towards the “-” indicates a lower setting. The first two settings (- and the one next to it) are typically used for sound suppressors, and the other 3 to adjust for ammunition or environmental conditions.

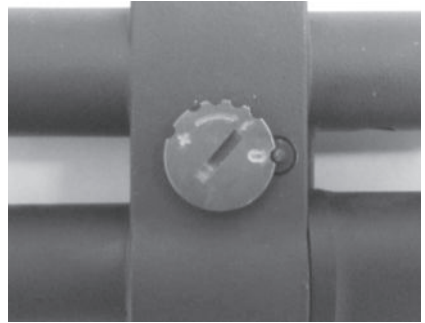

Changing Gas Settings

1. Unload the Rifle according to Pages 15-16 and use the Bolt Catch to hold the Bolt Carrier in the rearward position.
2. Depress the Gas Valve Detent with the tip of a cartridge while rotating the valve to the desired setting with the rim of another cartridge as shown.
3. After you have rotated the Gas Valve to the desired setting, release the Gas Valve Detent.
4. After releasing the Gas Valve Detent, you should not be able to rotate the Gas Valve.

Break In It is recommended that the gas setting be left the “+” setting for at least the first 100 to 200 rounds.

TO ENSURE THE MILDEST RECOIL WITHOUT SACRIFICING RELIABILITY, USE THE GAS SETTING WHICH THROWS THE SPENT CARTRIDGE CASES CLEAR OF THE FIREARM WITHOUT JAMMING. IF YOU FEEL TRIGGER SLAP, THE GAS IS SET TOO HIGH.

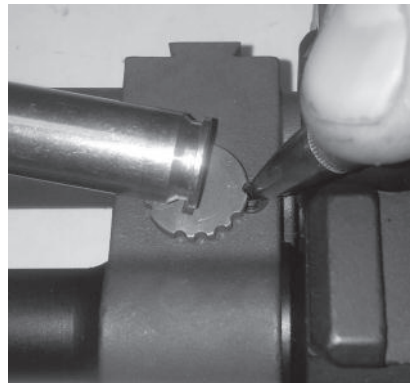

WARNING

REMOVING THE MAGAZINE FROM THE RIFLE DOES NOT MEAN THE RIFLE IS UNLOADED AS THERE MAY STILL BE A ROUND IN THE CHAMBER. ALWAYS POINT THE WEAPON IN A SAFE DIRECTION WHILE UNLOADING THE RIFLE. WHEN PULLING BACK ON THE CHARGING HANDLE, ALWAYS MAKE SURE THE EJECTION PORT IS FACING THE GROUND. CARTRIDGES ARE EJECTED WITH FORCE. WEAR EYE PROTECTION AT ALL TIMES.

1. Remove the Magazine completely from the Rifle by depressing the Magazine Release. The Magazine should fall out of the Weapon of its own weight.



2. With the ejection port facing the ground, pull the Charging Handle all the way back with one hand and engage the Bolt Catch by pushing it upward with the index finger of the other hand. The bolt should stay open.



3. Rotate the Safety Selector so that the Indicator is next to the image of a bullet with an "X" through it. This is the Safe position.

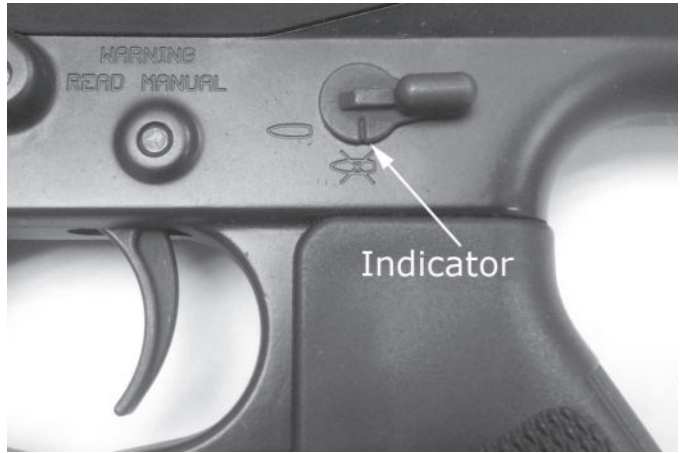

4. Check the chamber to make sure it is empty.



WARNING

BEFORE DISASSEMBLING THE WEAPON, MAKE SURE THE WEAPON HAS BEEN UNLOADED (SEE PAGES 15-16). DO NOT HANDLE, DISASSEMBLE, OR ASSEMBLE THE RIFLE WITHOUT WEARING PROPER EYE PROTECTION.

Bolt Carrier Assembly Removal

1. While pushing the Receiver Lock toward the Barrel of the Weapon, rotate the Lower Receiver Away from the Upper Receiver.



2. Tip the Barrel up and let the Bolt Carrier Assembly slide out of the Upper Receiver. Be ready to catch the internal parts as they slide out. As they slide out, hold the Operating Rod firmly against the Bolt Carrier.



Bolt and Operating Rod Removal

1. Remove the Operating Rod from the Bolt Carrier.

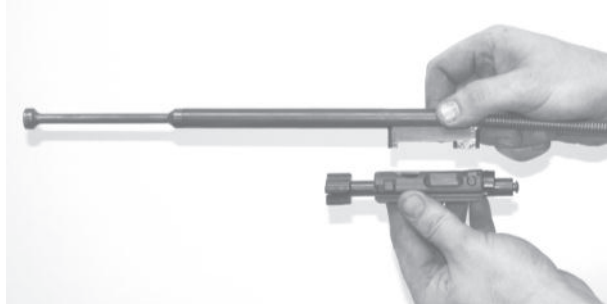

2. Remove the Bolt from the Bolt Carrier.



3. Remove the Recoil Spring from the Operating Rod.



Extractor Removal

Remove the extractor by using a 5/64" flat nosed brass punch to force the extractor away from the center of the bolt while pushing in on the Extractor Detent. The Extractor Detent is not visible until the Extractor is moved toward the outside of the Bolt.

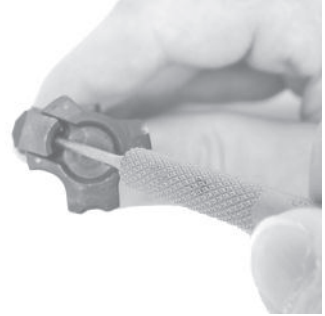

Firing Pin Module Removal

The firing pin is mounted in the Firing Pin Module. It is recommended that you do not remove the Firing Pin from the Firing Pin Module. To remove the Firing Pin Module from the Bolt Carrier, follow these steps:

1. Using the tip of a cartridge or punch, push the Firing Pin Module Retaining Pin from the Bolt Carrier.

2. Pull the Firing Pin Module from the Bolt Carrier.



3. Remove the Recoil Buffer from the Bolt Carrier

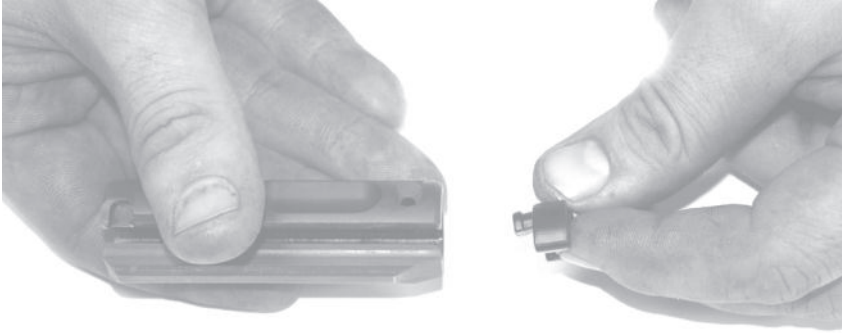

WARNING

MAKE SURE THE BARREL IS COOL BEFORE TOUCHING IT.

Barrel Removal

1. Using an 1/4" allen wrench, unscrew the Barrel Lock Bolt out approximately 1/4" or 3 full turns. It is not necessary to remove the Barrel Lock Bolt completely.

(Note: The Bolt Carrier must be Removed or retracted before the Barrel can be removed.

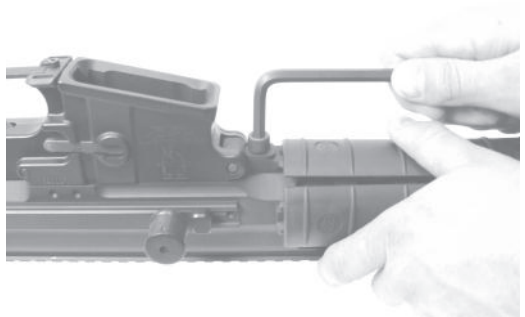

2. Slightly rotate the barrel back and forth to break it loose. Then pull it out of the barrel



Removal of Gas Tube

Pull the Gas Tube out of the Upper Receiver.



Gas Piston & Gas Valve Removal

Using a 3/8 closed end wrench, turn the Gas Cap counter clockwise and remove the Gas Cap from the Gas Block.

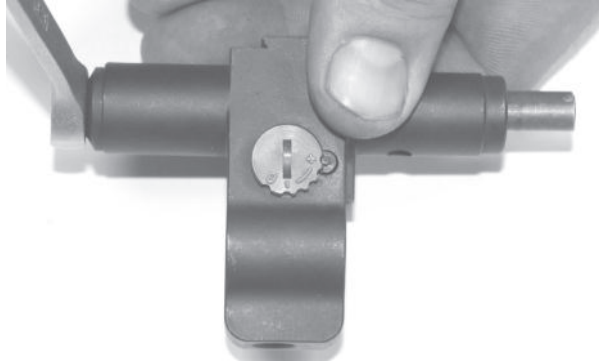

Slide the Piston out of the Gas Block.

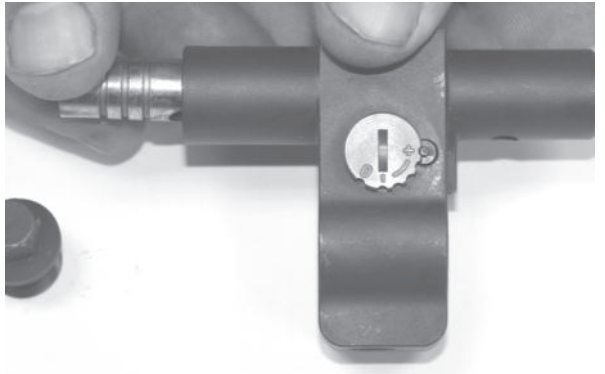

Remove the “C” Clip from the Gas Valve. Constrain one end of the C Clip with your finger and use a plastic tool to push the other end off as shown. Note: There is generally no need to remove and clean the Gas Valve unless the Gas Valve becomes very difficult to turn or the Gas Adjustment doesn't seem to be working.

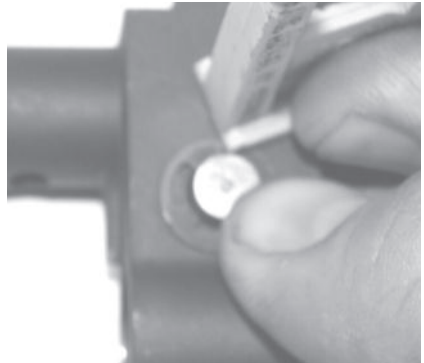

Removal of the Lower Receiver

With the tip of a cartridge or with your finger, push the Receiver Pin from Left to Right until it clicks into place. THE PIN IS MEANT TO BE RETAINED IN ONE SIDE OF THE LOWER RECEIVER.



WARNING

REMOVAL AND REPLACEMENT OF THE FIRE CONTROL PARTS SHOULD ONLY BE DONE BY A COMPETANT GUNSMITH.

MODIFICAITON OF ANY PART IS DANGEROUS , VOIDS ALL WARRANTIES, AND MAY BE ILLEGAL.

DO NOT DRY FIRE THE RIFLE WHILE WITH THE UPPER RECEIVER NOT ATTACHED TO THE LOWER RECEIVER.

WARNING

DO NOT HANDLE THE RIFLE OR ANY PARTS WITHOUT WEARING PROPER EYE PROTECTION.

DO NOT ATTEMPT TO CLEAN, LUBRICATE OR INSPECT THE RIFLE WITHOUT FIRST UNLOADING THE RIFLE AND REMOVING THE BOLT CARRIER ASSEMBLY (SEE PAGES 15-23).

DO NOT FIRE THE RIFLE IF ANY PART LOOKS DAMAGED IN ANY WAY.

Barrel

The Barrel may be cleaned while it is connected to the Upper Receiver or after it has been removed. It is always best to clean a barrel from the chamber end.

1. Run a cleaning rod with a wire brush soaked with a bore cleaner, through the bore several times. Push the brush completely through the bore. Do not stop part way through the bore and change directions.
2. Next run a dry cloth through the bore. Then alternate running cloths wet with bore cleaner and dry cloths through the bore until the cloths come out clean.
3. Repeat step 2. until the cloth comes out clean.
4. Then run one cloth slightly oiled down the barrel.
NOTE: Do not leave harsh cleaners in the bore for more than 5 minutes as they may damage it.
5. Inspect the Bore and Chamber for obstructions.

Barrel Extension

1. The Barrel Extension can be cleaned with a toothbrush and powder solvent. Lightly lubricate the Barrel Extension with light oil wiping away any excess lubricant.
2. Inspect the Barrel Extension for cracks or other damage.

Gas Block & Gas Valve

The Gas Block including the Piston and the Gas Valve do not need cleaning unless:

1. The Piston will not slide in and out of the Gas Block on its own..
2. The Gas Valve is very difficult to turn. Or
3. Recoil is excessive even on low Gas Valve Settings.

To clean the Gas Block, Piston, and Gas Cap, use a powder solvent (carbon dissolving) cleaner, such as Slip 2000 725 Gun Cleaner & Degreaser, to remove the carbon buildup from inside and outside of the Parts. **DO NOT SCRAPE OR SAND THE OUTSIDE OF THE GAS PISTON.** If your Carbon dissolving cleaner is not doing the

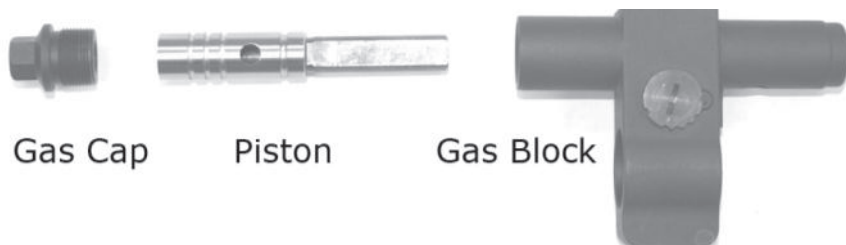

job, you may use the following off the shelf drill bits to make sure the holes of these parts have the carbon removed. These drill bits should be turned by hand. **DO NOT USE A DRILL OR OTHER POWER TOOLS.** If you increase the diameter of the holes in these parts, the firearm may not function.

Drill Bit Size	Use to Clean Out Hole on Part
29/64	Large Hole in Gas Block
5/64	Piston and Gas Cap
No. 11 (.1910)	Small Hole in Piston

Gas Tube

1. Run a large copper brush wet with powder solvent through the Gas Tube several times. Push the Brush through the gas tube completely each time.
2. Then alternate pushing dry and wet cloths through the Gas Tube until the cloth comes out clean.
3. Repeat 1 & 2 above until clean.
4. Wipe residual powder solvent from the Gas Tube. Only slightly lubricate the gas tube. Excess lubrication will only burn off.

WARNING

IF ANY PART OF THE BOLT OR FIRING PIN MODULE APPEAR TO BE DAMAGED IN ANY WAY OR THE FIRING PIN DOES NOT MOVE FREELY, DO NOT CONTINUE TO FIRE THE RIFLE.

Bolt

1. Clean the Bolt with powder solvent.
2. Lightly Lubricate wiping off any excess lubricant.
3. Inspect the bolt cam and lugs for cracks. If cracks or other damage is found, replace the Bolt.

Firing Pin Module

1. Clean the Firing Pin Module with powder solvent. When the head of the Firing Pin is depressed, it should move in and out of its housing freely without binding. IF IT BINDS AT ALL, DO NOT USE IT. It is not recommended nor is it necessary to disassemble the Firing Pin Module for cleaning.



2. After cleaning, lubricate lightly and wipe off excess lubricant..

Extractor

It is NOT necessary to remove the Extractor for normal cleaning. If you do remove it to check for wear and cracks, clean with powder solvent and wipe away all excess residue before re-assembly.

Bolt Carrier and Operating Rod

1. Clean bolt Carrier and Operating Rod with a brush and powder solvent.
2. Lubricate all the way along the Carrier and Operating Rod on both sides at the points shown before installing them in the Upper Receiver.

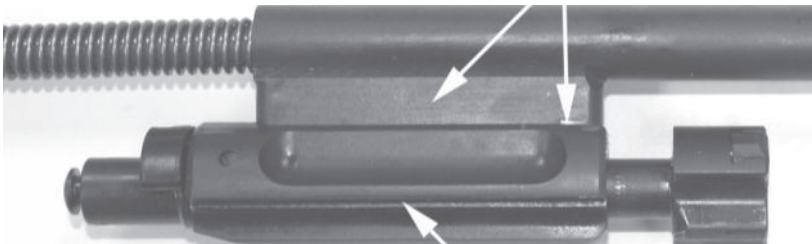

Upper Receiver

1. Clean the Upper Receiver with a powder solvent or in a part cleaning tank. **DO NOT USE A WIRE BRUSH.**
2. Wipe off residue.
3. Lubricate with LSA or other light lubricant. **DO NOT USE GRAPHITE LUBRICANTS.**
4. Check the bolts on the following parts to make sure they are tight:

Ejector Bolts

Make sure the Ejector is not loose. If it is, remove the bolts, use Loctite 242, and tighten the Ejector Bolts. You will need to use your Bolt Carrier and Bolt to position the Ejector.

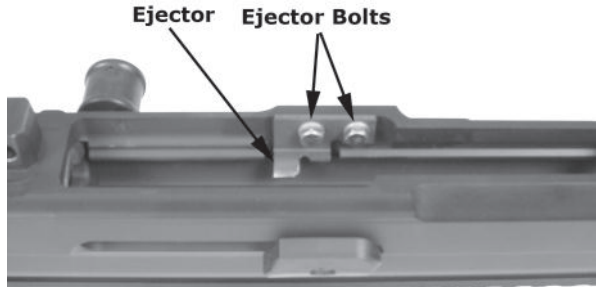

Brass Deflector

Tighten the Brass Deflector bolt with an allen wrench. Use Loctite 222 on the threads of the bolt only. Once it begins to feel tighter, turn 1/4 turn more. **DO NOT OVERTIGHTEN.** If you tighten too much, the bolt can hit the carrier inside the receiver.

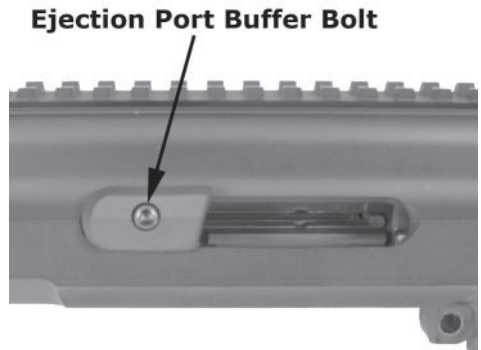

Lower Receiver

1. Clean the lower receiver with powder solvent or in a parts cleaning tank.
2. Wipe off residue.
3. Lubricate with light lubricant, wiping off excess lubricant.
4. Check the following bolts and the receiver buffer to make sure they are tight and not damaged:

Stock and Selector Bolts

Make sure the Stock and Selector Bolts are not loose. If they are, remove, use Loctite 242, and then re-tighten the bolts.

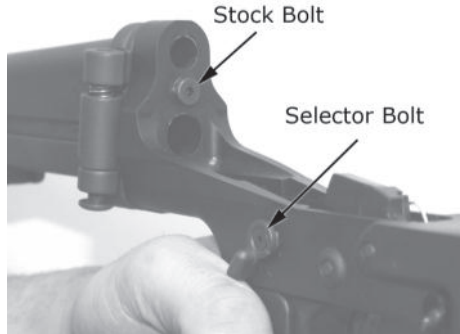

Bolt Catch Bolt

Make Sure the Bolt Catch Bolt is Tight. (Note: The Bolt Catch itself is meant to have lots of wiggle room.) If the Bolt Catch Bolt is loose, remove it, use Loctite 222, and then re-tighten it.

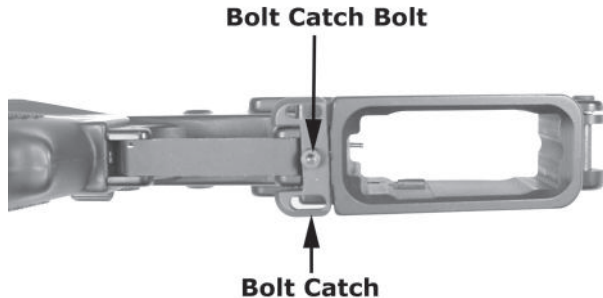

WARNING

DO NOT HANDLE THE RIFLE OR ANY PARTS WITHOUT WEARING PROPER EYE PROTECTION.

Gas Block Assembly

1. Slide the Piston into the Gas Block.
2. Screw on the Gas Cap
3. Tighten hand tight then 1/4 Turn. Note: No Loctite is needed.
4. If the Gas Valve has been removed, Insert it into the Gas Block and Replace the C Clip.

Barrel Installation

1. Slide the barrel into the Upper Receiver. The Gas Block should line up with the Gas Tube as shown in the image to the right.

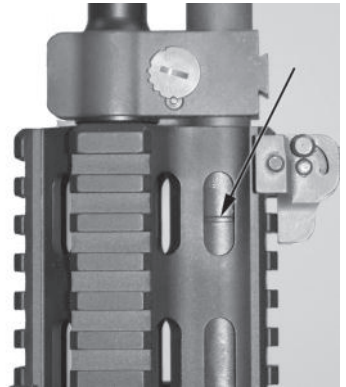

2. Screw in the Barrel Bolt with a 1/4" Allen wrench. Lightly hand tighten the screw. Over tightening can ruin the Upper Receiver. Use a maximum of 200 inch pounds. If you do not have a torque wrench, turn till hand tight then try to turn another 70 degrees by hand to ensure barrel is in tight.



WARNING

DO NOT FORGET TO INSTALL THE RECOIL BUFFER. MAKE SURE THE FIRING PIN MOVES IN AND OUT OF THE FIRING PIN MODULE FREELY.

Bolt Assembly

1. Insert the Recoil Buffer into the Bolt Carrier.

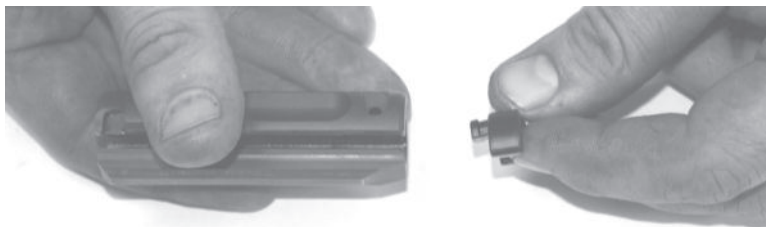

2. Insert the Firing Pin Module into the Bolt Carrier. You may have to twist it some to get it past the Recoil buffer.



3. Align the Firing Pin Module with the hole in the Bolt Carrier and Insert the Firing Pin Module Retaining Pin. Push in the Firing Pin several times to make sure it moves freely. It should be quite stiff but move in and out without getting stuck.



4. While depressing the Extractor Detent with the tip of a 5/64" flat nosed brass punch, slide the Extractor into its groove in the Bolt. Slide the Extractor in until it snaps into place.



Bolt Carrier Assembly

1. Slide the Bolt Into the Bolt Carrier..



2. Slide the Recoil Spring into the Operating Rod.



3. Fit the Operating Rod to the Bolt Carrier.

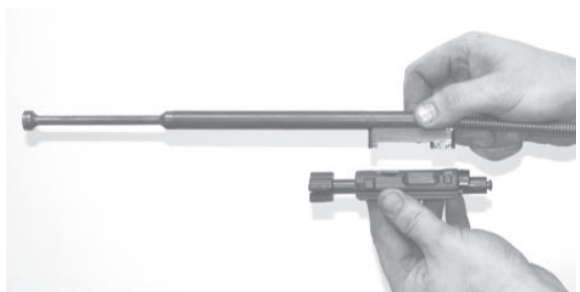

Lower Receiver Installation

1. Align the hole in the front of the Lower Receiver with the hole at the midpoint of the Upper Receiver.
2. Push the Axis Pin of the Lower Receiver through the Upper Receiver.

Operating System Installation

Holding the Bolt Carrier and Operating Rod together with the Bolt Carrier fully extended, slide the Bolt Carrier Assembly into the Upper Receiver.



WARNING

FOLLOW THE INSTRUCTIONS ON PAGE 12 TO ENSURE THE UPPER AND LOWER ARE PROPERLY LOCKED.

Locking the Upper Receiver and Lower Receivers.

1. Depress the Receiver Lock and simultaneously rotate the Upper Receiver towards the Lower Receiver.
2. Once the Upper and Lower mate, release the Receiver Lock.



1913 Standard Rails

The Upper Receiver of the Rifle comes equipped with 1913 Standard (“Picatinny”) Rails at the 3, 6, 9, and 12 O’clock positions.

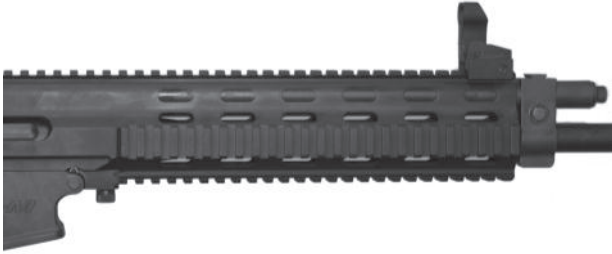

The XCR does not come with any accessories on the Rails unless you order them separately. Almost any accessory made for the M16/M4 type rifles can be attached to the Rails. The list includes, but is not limited to:

- Front and Rear Iron Sights,
- Optical Sights,
- Night Vision Equipment,
- Laser Sights,
- White Lights,
- Rail Covers,
- Forward Vertical Grips,
- Bipods,
- Grenade Launchers, and
- Shotguns.

These accessories can be purchased through Robinson Armament Co. and other vendors.

NOTE: The rails can be damaged if accessories are not properly installed.

Compatible M16/M4 Accessories

In addition to accessories which attach to the Rails, there are other M16/M4 accessories which are compatible with the. These are as follows: most pistol grips, and most barrel compensators and flash hiders.

Additionally, Robinson Armament Co. offers a stock adapter which will allow the installation of most M4 buttstocks which use the standard M4 buttstock tube.

WARNING

Caliber Conversion Kits

WHEN INSTALLING A CALIBER CONVERSION KIT, MAKE SURE TO THE AMMUNITION YOU ARE USING MATCHES THE CALIBER OF THE BARREL YOU ARE USING.

The XCR-M was designed to fire almost any cartridge based on the .308 cartridge case. Since all these cases have the same head and rim, it is only necessary to change the barrel when changing calibers. For some calibers or configurations, a different brass deflector may also be needed.

Barrels for the XCR-M are marked with the caliber and rate of twist on the top of the barrel near the muzzle device.

Follow these instructions to change the caliber.



Disassembly.

1. Unload the Rifle. Follow instructions on pages 15-16.
2. Remove the Barrel. Follow instructions on pages 20-21.
3. Replace the Brass Deflector if necessary.

Re-assembly.

1. Install the Barrel of the new caliber. Follow instructions on page 31.



XCRs are now equipped with a fully adjustable stock (FAST). It is deployed and folded by means of a Button located on the bottom of the hinge mechanism.

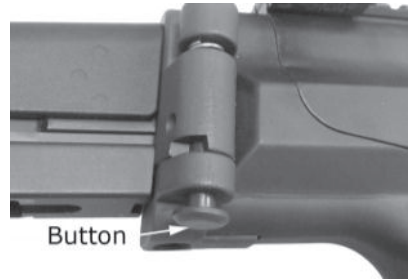

To fold the stock remove the stock from you shoulder, and push the button upward. Note: if you put any pressure on the stock, you will have a difficult time pushing up on the button.



To deploy the stock, push the button upward and flick the stock into place with you trigger finger. Or, raise the rifle vertically and push the button up. The stock will swing into place.



On the bottom of the FAST Stock is the Stock Length Adjustment Button. When depressed, the stock can be adjusted for length. Also found on the bottom of the Stock is a hole where a QD Sling Swivel may be attached. Additional sling mounting points can be added to the 1913 Rails.

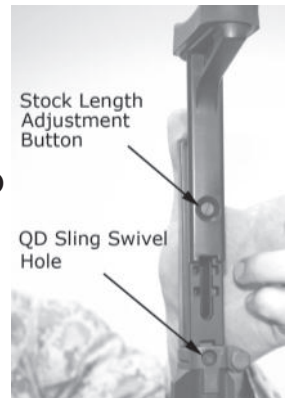

WARNING

DO NOT ATTEMPT TO TROUBLESHOOT ANY MALFUNCTION OF THE RIFLE UNTIL THE RIFLE HAS BEEN UNLOADED ACCORDING TO PAGES 15-16. ALWAYS KEEP THE RIFLE POINTED IN A SAFE DIRECTION.

IF THE RIFLE MALFUNCTIONS AFTER FOLLOWING THIS TROUBLESHOOTING SECTION, STOP SHOOTING IMMEDIATELY AND CONTACT THE MANUFACTURER.

IF THE RIFLE DOUBLE FIRES OR SLAM FIRES, STOP SHOOTING IMMEDIATELY AND CONTACT THE MANUFACTURER.

The Malfunction Matrix on the next page lists some possible malfunctions, gives their probable causes, and states likely solutions. The following are some definitions used:

Bolt Over Base. This occurs when the Bolt does not get behind the base of the next round in the magazine. The Bolt strikes the body of the next round but does not chamber it.

Empty Case in Chamber. This occurs when the Bolt does not travel far enough for the case to hit the ejector. Consequently, the empty and expanded case is shoved back into the chamber where it sticks. To clear this case from the chamber, hit the Charging Handle with the side of your hand or with some other soft object.

Empty Case Caught in Action. Some refer to this as a stove pipe. The case was extracted from the chamber but not ejected from the receiver.

Bolt Catch Doesn't Catch. When the bolt does not stay open (or Catch) after the last round is fired.

MALFUNCTION MATRIX

Malfunction/Symptom	Cause	Solution
Bolt Over Base	Gas Adjustment set too low	Set Gas Adjustment Higher
	Excessively Dirty Upper Receiver	Clean
	No Lubrication	Lubricate
Empty Case in Chamber	Gas Adjustment set too low	Set Gas Adjustment Higher
	Excessively Dirty Upper Receiver	Clean
	No Lubrication	Lubricate
Empty Case Caught in Action	Gas Adjustment set too low	Set Gas Adjustment Higher
	Excessively Dirty Upper Receiver	Clean
	No Lubrication	Lubricate
Bolt Catch Doesn't Catch	Ejector has come loose	Locite & Tighten
	Parts have come loose	Locite & Tighten
	Parts are missing	Replace Parts
Double Fire or Slam Fire – STOP SHOOTING IMMEDIATELY	Firing Pin Module damaged	Fix or Replace Parts
	Firing Pin Spring is not working.	

LIMITED ONE YEAR WARRANTY

Robinson Armament Co. warrants to the initial retail purchaser that the Rifle will be free of defects in material or workmanship for a period of one year from the date of purchase.

This warranty shall not cover any damage or condition determined by Robinson Armament Co. to be caused by carelessness, negligence, misuse, normal wear and tear, or failure to properly maintain the product, or by unauthorized repairs or modifications. The foregoing warranty is exclusive and in lieu of all other warranties of quality, whether written, oral, or implied including but not limited to any warranty of merchantability or fitness for purpose.

LIABILITY DISCLAIMER

Robinson Armament Co assumes no responsibility for damage and/or injury caused in whole or part by hand-loaded, reloaded, remanufactured, military surplus, or defective ammunition (“Improper Ammunition”). Under no circumstances shall Robinson Armament Co. be held responsible for incidental or consequential damages with respect to economic loss, injury, or damage to property, arising out of the use of Improper Ammunition, unsafe handling, misuse or unauthorized modifications to the Rifle. Robinson Armament Co. and shall not be responsible for damage or injury resulting from careless handling, unauthorized repairs or modifications, corrosion, neglect, or misuse. Robinson Armament Shall not be held responsible for any unlawful possession or use of the Rifle.

ROBINSON ARMAMENT CO.’S OBLIGATIONS WITH RESPECT TO THE RIFLE ARE STRICTLY LIMITED TO THE FOREGOING ONE YEAR WARRANTY. THE FOREGOING WARRANTY IS THE ONLY WARRANTY MADE BY ROBINSON ARMAMENT CO. AND ROBINSON ARMAMENT CO. DOES NOT MAKE AND YOU HEREBY EXPRESSLY WAIVE ALL OTHER WARRANTIES, EXPRESS OR IMPLIED, INCLUDING THE IMPLIED WARRANTIES OF MERCHANTABILITY AND FITNESS FOR A PARTICULAR PURPOSE.

LIMITATIONS OF LIABILITY. ROBINSON ARMAMENT CO. SHALL NOT HAVE ANY LIABILITY WITH RESPECT TO ITS OBLIGATIONS UNDER THIS AGREEMENT OR OTHERWISE FOR LOSS OF GOODWILL, OR FOR SPECIAL, INDIRECT, CONSEQUENTIAL, OR INCIDENTAL DAMAGES, WHETHER IN TORT OR IN CONTRACT, EVEN IF ADVISED OF THE POSSIBILITY OF SUCH DAMAGES. IN NO EVENT SHALL ROBINSON ARMAMENT CO.’S LIABILITY UNDER THIS AGREEMENT EXCEED THE AMOUNT PAID OR PAYABLE BY YOU FOR THE RIFLES UNDER THIS

AGREEMENT. WITHOUT LIMITING THE GENERALITY OF THE FOREGOING, ROBINSON ARMAMENT CO. SHALL NOT BE LIABLE FOR AND YOU SHALL DEFEND, INDEMNIFY AND HOLD ROBINSON ARMAMENT CO. HARMLESS FROM ANY DAMAGE OR INJURY WHICH RESULTS FROM THE IMPROPER USE OF THE PRODUCTS, MODIFICATION TO THE PRODUCTS, ILLEGAL USE OF THE PRODUCTS, OR FAILURE TO FOLLOW THE WARNINGS CONTAINED IN THE OPERATORS' MANUAL FOR THE PRODUCTS.

By using the Rifle you acknowledge that you have read the Owner's Manual including all warnings and instructions and that you agree to these terms and conditions. It is your responsibility to understand, possess and use the rifle in compliance with all applicable federal, state, and local laws.

To receive warranty coverage, you must register your Rifle with Robinson Armament Co. by copying this page and the adjacent page, signing it and mailing or electronically transmitting it to Robinson Armament Co. with the information below.

First Name: _____

Last Name: _____

Address: _____

City: _____

State: _____

Zip: _____

Daytime Phone: _____

Date of Purchase: _____

Dealer Name: _____

Dealer Address: _____

Model: _____

Serial #: _____

Signature: _____

Phone: 801-355-0401

Fax: 801-337-2281

Email: sales@robarm.com

ROBINSON ARMAMENT CO.

WWW.ROBARM.COM

TEL: 801-355-0401 Email: sales@robarm.com